

## CMT1801

NO.	DESCRIPTION	SPEC.
1	THREAD SLEEVE	
2	SPRING WASHER	
3	INNER GEAR RING	
4	SPRING	
5	SCREW	M4X10
6	MOTOR SUPPORT	
7	COUPLER	
8	MOTOR	
9	POSITIVE/NEGATIVE ROD	
10	SAFETY BUTTON	
11	BUTTON SPRING	
12	REVERSE PUSH BUTTON	
13	SWITCH	
14	LED COVER	
15	LED	
16	SCREW	ST3X12
17	HOUSING	
18	SCREW	M4X10
19	HOOK	
20	LEFT CONNECTION PLATE	
21	NUTM4	
22	CONNECTOR BRACKET	
23	RIGHT CONNECTION PLATE	
25	SCREW	ST3X14
101	2-SPEED DRILL ATTACHMENT	
102	MULTI-FUNCTION TOOL ATTACHMENT	
103	MOUSE SANDER ATTACHMENT	
104	JIG SAW ATTACHMENT	

CMT1801-EX-RU20210830

Sturm!  
нас рекомендуют друзья

Sturm!  
нас рекомендуют друзья

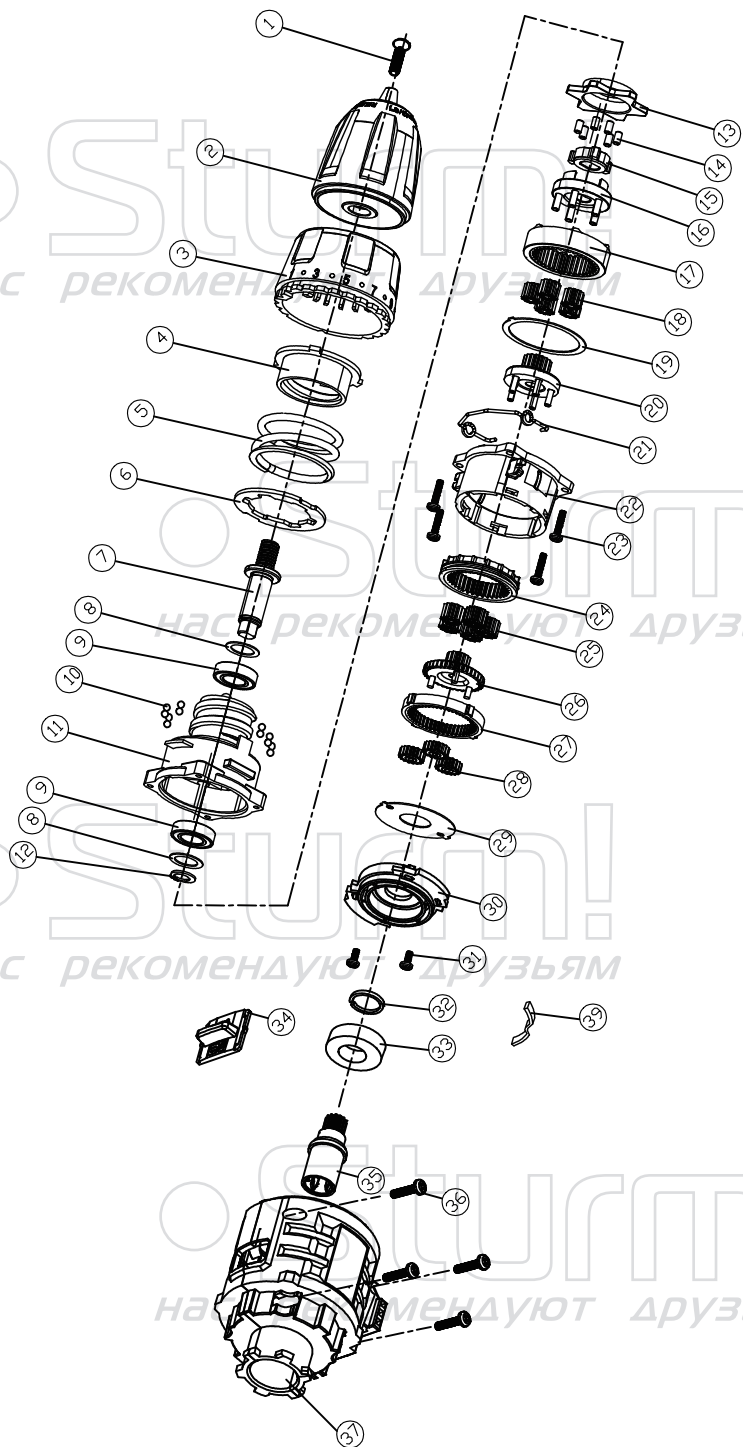

## CMT1801 (Drill Function)

NO.	DESCRIPTION	SPEC.
1	SCREW	M6*25
2	13MM CHUCK	
3	TORQUE RING	
4	TORQUE RING THREADED INNER SLEEVE	
5	TORQUE SPRING	
6	TORQUE GASKET	
7	OUTPUT SHAFT	
8	GASKET	10.2*13.2*0.5
9	BEARING	6800
10	STEEL BALL	Ø 5.0
11	GEAR BOX FRONT HOUSING	
12	CIRCLIP	Ø10
13	LOCKING SLEEVE	
14	PIN	Ø3x Ø5.4
15	LOCKING PLATE	
16	LOCKING FRAME	
17	THIRD PLANETARY GEAR RING	
18	THIRD PLANETARY GEAR	
19	THIRD PLANETARY RING GEAR GASKET	
20	THIRD LAYER MIDDLE GEAR	
21	ROCKING LEVER	Ø 1.4
22	GEAR BOX REAR HOUSING	
23	SCREW	ST3x9
24	SECOND LAYER GEAR RING	
25	SECOND LAYER PLANETARY GEAR	
26	SECOND LAYER MIDDLE GEAR	
27	FIRST LAYER GEAR RING	
28	FIRST LAYER PLANETARY GEAR	
29	FIRST LAYER RING GEAR GASKET	
30	GEAR BOX COVER	
31	SCREW	ST3*8
32	CIRCLIP	
33	BEARING	6901
34	HIGH/ LOW- SPEED BUTTON	
35	COUPLER	
36	SCREW	ST3.5*14
37	HOUSING	
39	GASKET 0.5MM	

CMT1801-EX-RU20210830

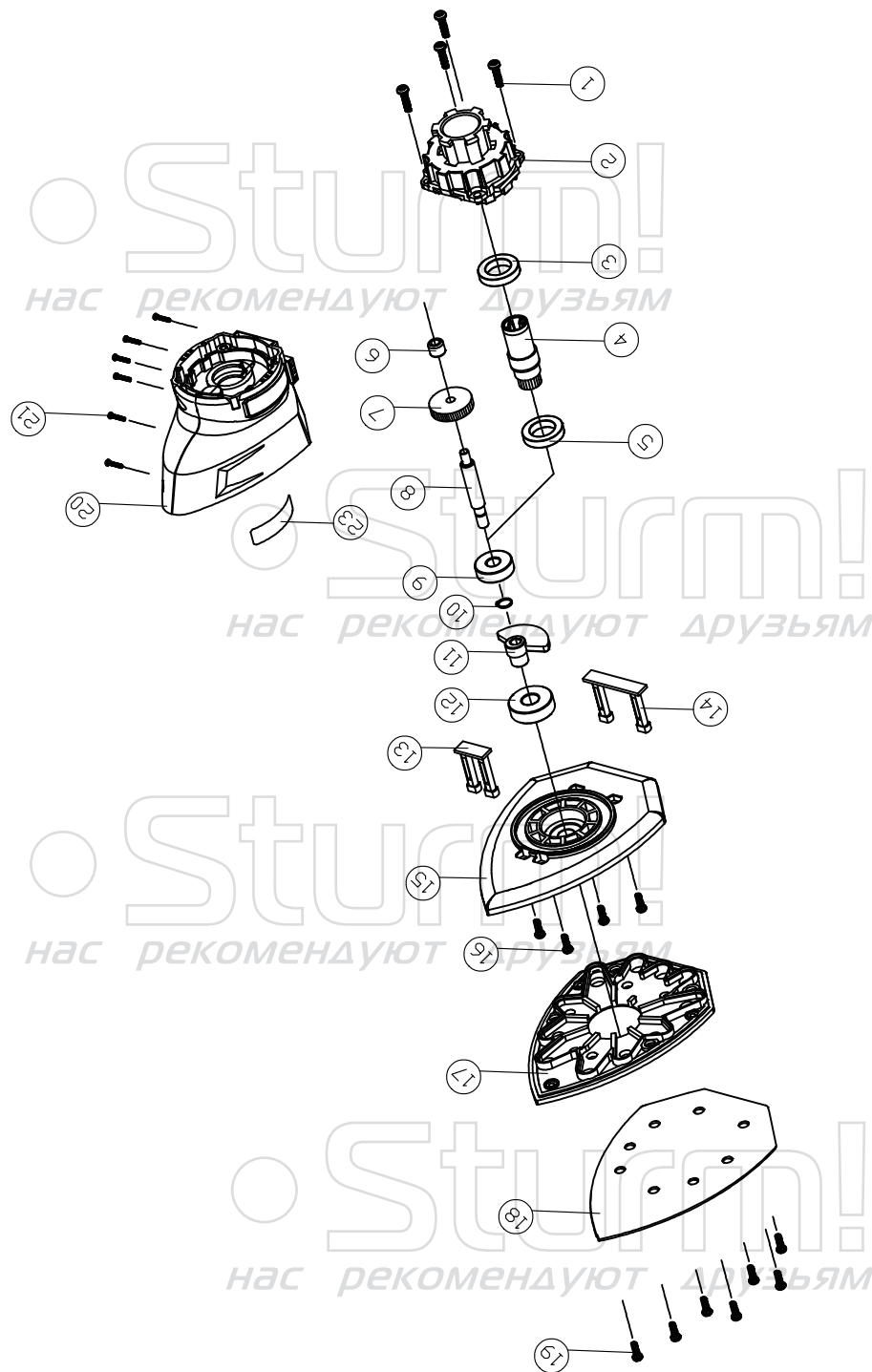

## CMT1801 (Sander Function)

NO.	DESCRIPTION	SPEC.
1	SCREW	ST4*12
2	CONVEX LOCK	
3	BEARING	6802
4	COUPLER	
5	BEARING	6802
6	NEEDLE ROLLER BEARING	
7	BIG GEAR	
8	SHAFT	
9	BEARING	608
10	SPRING FOR SHAFT	
11	COUNTERBALANCE	
12	BEARING	6000
13	NARROW SWING	
14	WIDE SWING	
15	UPPER PLATE	
16	SCREW	ST3*10
17	UNDER PLATE	
18	SANDPAPER	
19	SCREW	ST3*10
20	RIGHT	
21	SCREW	ST3.5**14
22	HOUSING	
23	LOGO LABEL	

CMT1801-EX-RU20210830

Sturm!  
нас рекомендуют друзья

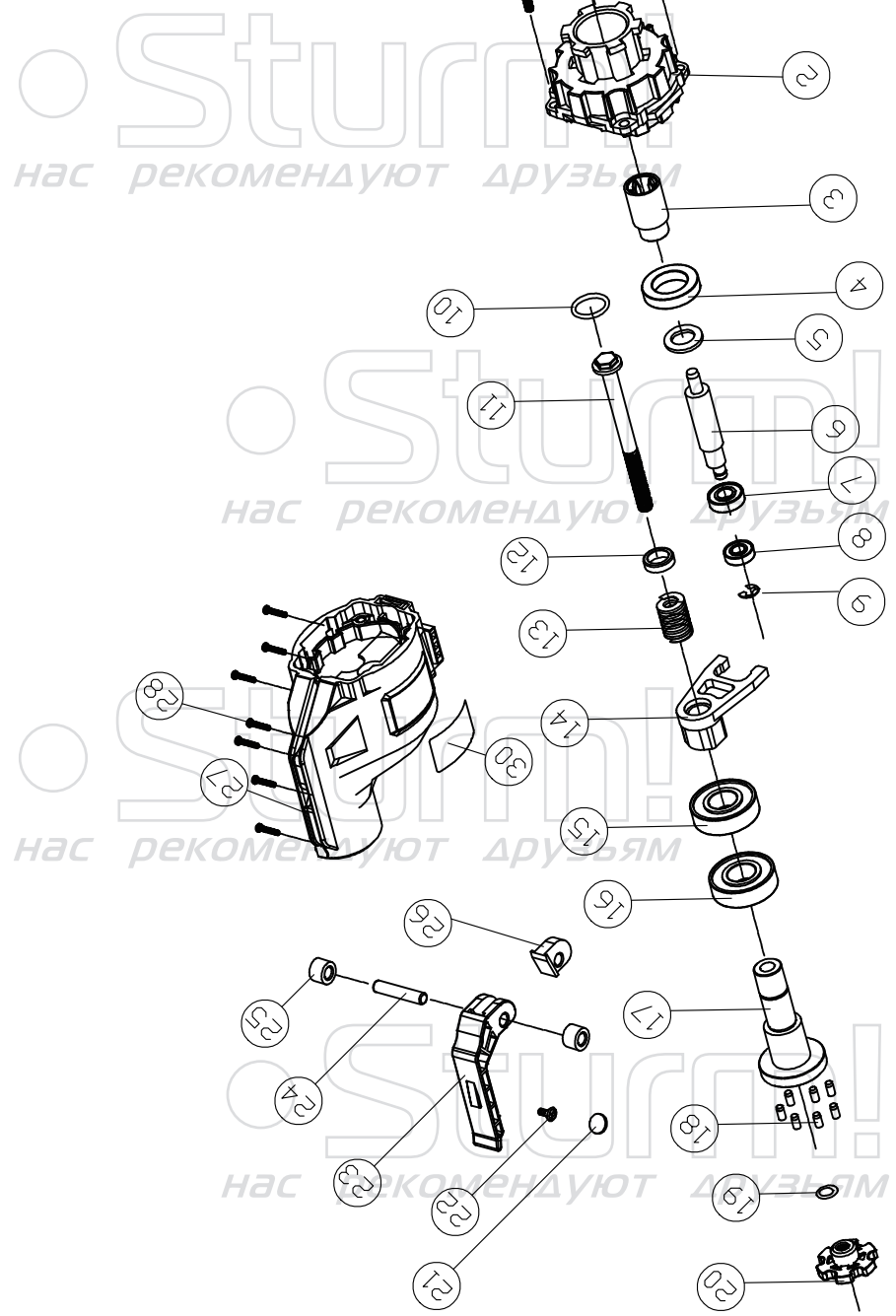

## CMT1801 (Multi-tool Function)

NO.	DESCRIPTION	SPEC.
1	SCREW	ST4*12
2	CONVEX LOCK	
3	COUPLER	
4	BEARING	6901
5	M8 WASHER	
6	ECCENTRIC SHAFT	
7	BEARING	608
8	BEARING	625
9	OPEN CIRCLIP	
10	SEALING RING	
11	BOLT	
12	SEALING COVER	
13	WIRE SPRING	
14	FORK	
15	BEARING	6001 B
16	BEARING	6001
17	SHAFT	
18	PIN	
19	BLANKET	
20	FLANGE	
21	MAGNET	
22	SCREW	ST3*8
23	TRIGGER	
24	PIN	
25	INNER STEEL SLEEVE	
26	CAM	
27	RIGHT HOUSING	
28	SCREW	ST3.5*14
29	LEFT HOUSING	
30	LOGO LABEL	

CMT1801-EX-RU20210830



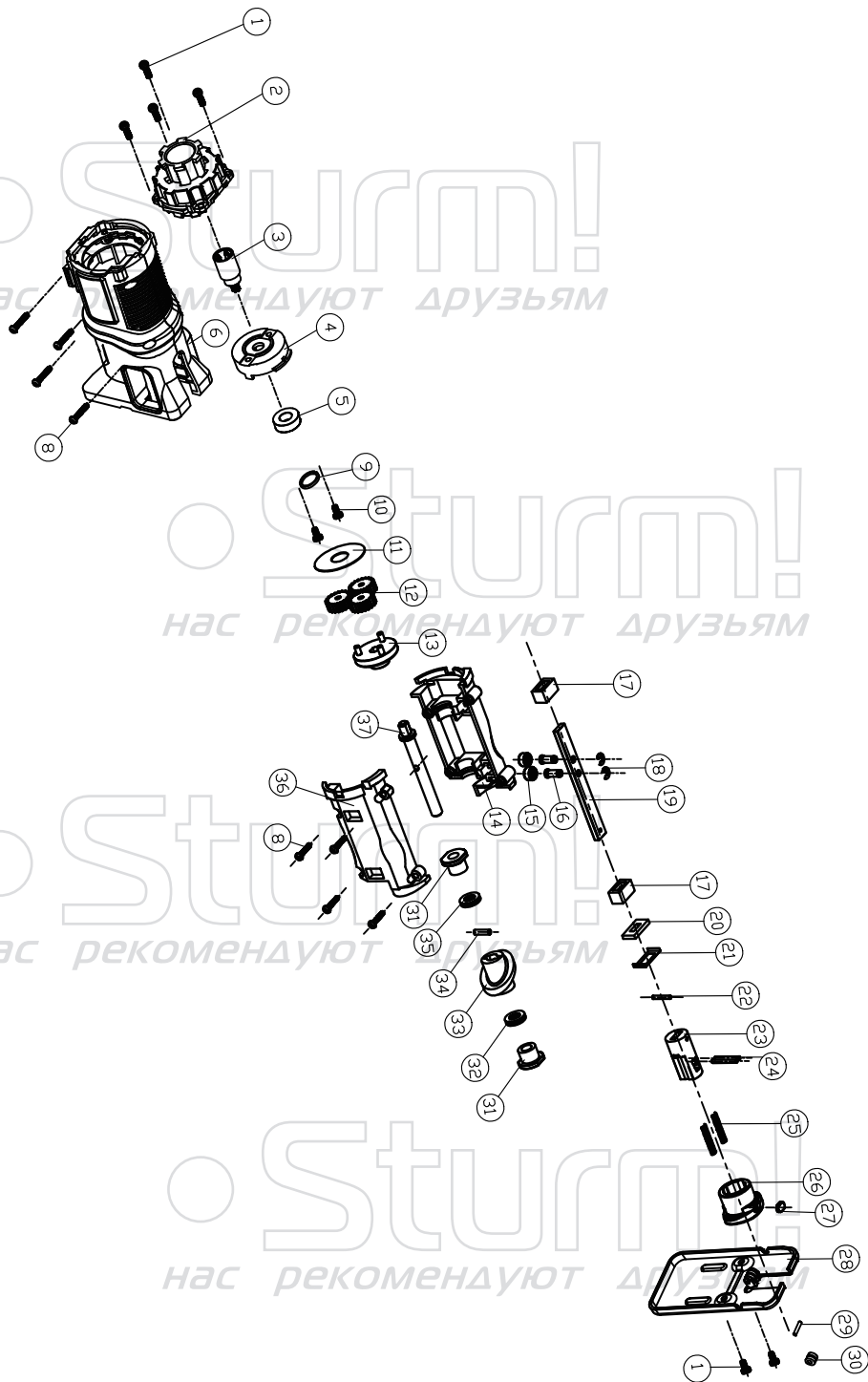

## CMT1801 (Jig saw Function)

NO.	DESCRIPTION	SPEC.
1	SCREW	ST4*14
2	CONVEX LOCK	
3	COUPLER	
4	GEAR BOX COVER	
5	BEARING	6901
6	HOUSING	
8	SCREW	ST3.5*14
9	SPRING FOR SHAFT	
10	SCREW	ST3*12
11	WASHER	
12	PLANET GEAR	
13	PLANET CARRIER	
14	GEAR BOX UNDER COVER	
15	SHAFT SLEEVE	
16	RECIPROCATING ROD BOX NAILS	
17	SLIDING SLEEVE	
18	SPLIT WASHER	
19	RECIPROCATING LEVER	
20	BLANKET CIRCLE	
21	SUPPORT	
22	PIN	
23	SAW BLADE CLAMP	
24	SAW BLADE CLAMP PIN	
25	SAW BLADE CLAMP SPING	
26	SLIDE SLEEVE	
27	SEALING PLUG	
28	BASE PLATE	
29	GUIDE WHEEL PIN	
30	GUIDE WHEEL	
31	BEARING SLEEVE	
32	NON-STANDARD BEARING	
33	DRIVE CAM	
34	PIN	
35	NON-STANDARD BEARING	
36	GEAR BOX UPPER COVER	
37	SHAFT	

CMT1801-EX-RU20210830